

**INSTALLATION MANUAL**

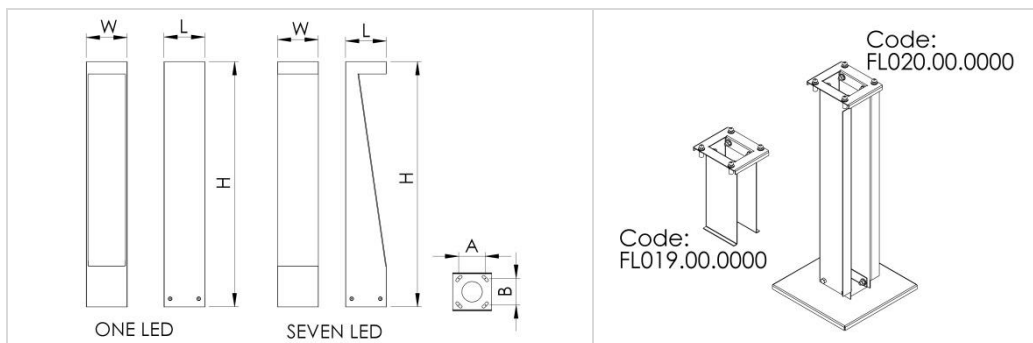

**ONE LED  
SEVEN LED**



220-240V / 50-60Hz

Typ	H	W	L	A	B	Weight [kg]
ONE LED	600	100	100	65	65	1,9
ONE LED	900	100	100	65	65	2,4
SEVEN LED	600	100	100	65	65	1,9
SEVEN LED	900	100	100	65	65	2,4

Light source in the fitting cannot be switched or replaced by anyone but manufacturer, his Service representative or similarly qualified personnel. Installation kit supplied with the luminaire does not include anchors for in-ground installation.

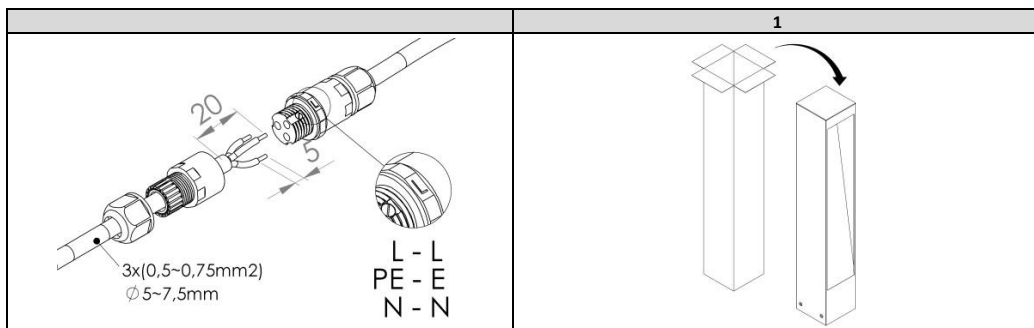

**Important warnings:**  
 The luminaires may be installed by qualified registered personnel only.  
 Any manipulation inside the luminaire when the power is activated causes the risk of electric shock.  
 The manufacturer is not responsible for any flaws resulting from non-compliance with these instructions.  
 The manufacturer reserves the right to change the construction of the product.  
 Do not install the luminaire in places without sufficient air circulation.  
 To guarantee safe luminaire functioning, please follow the instructions in the installation instructions.  
 PXF Lighting website: [www.pxf.pl](http://www.pxf.pl)

The European Directive 2002/96/EC on waste electrical and electronic equipment, requires that electric and electronic devices must be disposed of in the normal household waste. The crossed out wheeled bin is reproduced in order to remind obligations towards separate collection. For correct disposal, please use authorized waste disposal facilities or return to the distributor at the date a new lighting fitting is purchased. Lamps, if disposed together with the lighting fitting, shall not be broken up since they contain substances which are highly polluting to the environment. Unauthorized disposal of the foregoing waste material is punishable by law.

