

Installation manual

UNI LED



230V/50HZ

1. Dimensions

Power	A	B	C	Weight
LED 38W	595	595	45	5,5 kg / 6,25kg AW

2. Assembly

- a) carefully take the fixture out of box and put it on a stable surface (table, floor)
- b) take off the frame with a plate – ATTENTION! Frame has been installed on a magnets, to take it off pull it strongly and unbuckle hook protecting the frame
- c) connection of power supply
 - pull the feeding cable through the hole in the base of a fixture
 - connect the wires as shown on a cube

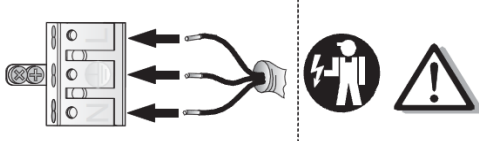

- d) mounting on the ceiling
 - fixture is installed to the ceiling through four 6,5mm holes of 500x500mm spread
- e) suspended mounting:
 - screw line regulators into 4 holes spaced 400x500mm
 - screw universal suspension on to the ceiling
 - delicately loosen regulator's outer nut, push the line in until the desired suspension height and tighten the nut. Putting line into the regulator will result with lifting of a fixture
 - To lower the fixture loosen the regulator's outer nut and push it towards the fixture – line will start coming out
- f) mounting in the suspended ceiling
 - cut the hole of size **605x605** mm
 - put the mounting frame in an screw the mounting holders on
 - screw the base of a fixture to the mounting frame through four 6,5mm holes of 500x500mm spread
- g) fasten the hook and close the fixture

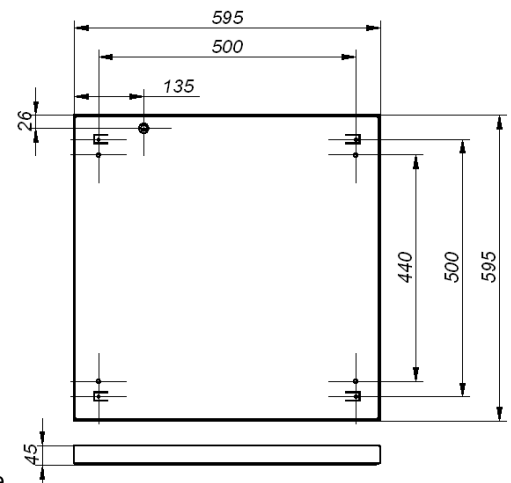

3. Important warnings:

The manufacturer cannot be considered liable for any damages deriving from improper, wrong and unreasonable use of the fitting. Luminaries may be installed by qualified personnel only. Any manipulation inside the luminaire when power supply is on causes the risk of electric shock. Manufacturer is not responsible for any flaws caused by avoid using this manual. Manufacturer reserves a right to change the construction of the product. Do not assembly in places without air circulation. To guarantee safety of fixture functions, please assembly according to instruction.



The European Directive 2002/96/EC on waste electrical and electronic equipment, requires that electric and electronic devices must be disposed of in the normal household waste. The crossed out wheeled bin is reproduced in order to remember obligations towards separately collection. For correct disposal, please use authorized waste disposal facilities or returned to the distributor at the date a new lighting fitting is purchased. Lamps, if disposed together with the lighting fitting, shall not be broken up since they contain substances which are highly polluting for the environment. Unauthorized disposal of the foregoing waste material is punishable by law.

